

Hanbell Compressor Installation and Start-up Guide

RC2-100 to RC2-930

1. Compressor Crate Unpacking & Inspection

- 1.1. Inspect crate and compressor for any shipping damage.
- 1.2. The compressor is in an easy open crate, cut straps and lift off crate top from base.
- 1.3. Use either steel cable or safety ropes to lift the compressor, see Figure 1. The cable should be capable of holding up to a minimum of 2 tons.

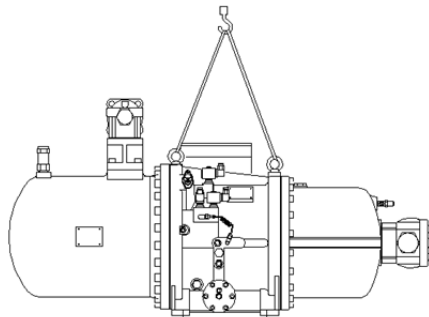

Figure 1 -Lifting Compressor with Steel Cable

Use caution while lifting the compressor

- ⇒ Make sure that the steel cable does not touch the **Solenoid Valves, Capillary, Oil Heater, Discharge Temperature Sensor and or Power Terminals, etc.** to prevent damage.
- ⇒ Use only steel cable or safety ropes to lift the compressor; make sure that the cable/rope has the proper strength to lift the compressor.
- ⇒ Keep the compressor horizontal while lifting.

- 1.4. Check compressor nameplate for correct model and voltage designation.
- 1.5. To facilitate customer installation requirements, the parts listed in Table 1 are factory supplied in separate boxes located in the compressor terminal box or packed in the compressor shipping container. Please verify that you have received all accessory parts.

Qty	Description
1	Stop Valve Assembly 1 stop valve, 2 gaskets, 1 charging valve, 4 bolts, 1 half union connector, 1 flare nut, 1 flare seal bonnet
1	Discharge bushing connector
1	Suction bushing connector
1	Motor Terminal Junction Box Assembly 1 terminal box, 1 motor protection, 2 plastic terminal plugs, 1 reset button, 4 wires (refer to Figure 4-B)

Table 1: Compressor Accessories & Service Valve Parts

2. Compressor Safety Instructions

- 2.1. Follow recognized safety procedures and practices.
- 2.2. In order to prevent the penetration of moisture, air or impurities, the compressor has been charged with Nitrogen gas. Do not remove any compressor bolts or fittings until the factory supplied holding charge has been relieved!
- 2.3. Do not apply any power to the compressor unless all valves are open and solenoids are energized (suction / discharge, service valves, economizer and oil shut off valves).
- 2.4. Do not operate or provide any electrical power to the compressor unless the terminal box cover is in place and secured. Measurements of the current and voltage during running conditions must be taken at other points in the power supply.
- 2.5. Do not remove terminal box cover until all electrical sources have been disconnected.

WARNING: Failure to follow these instructions could result in serious personal injury.

3. Installation Procedures

- 3.1. **Holding Charge:** The screw compressor is factory supplied with 7 psig (0.5 bar) holding charge of nitrogen gas. The internal pressure must be relieved before attempting to remove any compressor fittings or parts. Relieve the holding charge by removing the threaded cap on the low pressure Schrader connection fitting and depressing the internal Schrader stem.

CAUTION: This compressor may contain trace amounts of oil. Do not relieve the holding charge or open the compressor pots until it is ready to be connected to a closed dry system. Excessive moisture may shorten compressor life.

- 3.2. **Installation of the Compressor Electrical Terminal Box:** Four bolts located on the top of the electrical terminal box cover mount the electrical terminal box; it is adjustable to the cable hole direction to meet the power cables' optional connection direction from the chiller.
- 3.3. **Oils:** Adding and removing oil is done through the Drain valve located on the solenoid side of compressor. **The compressor has no oil and is not charged with oil.** When adding oil or doing a complete oil change, use only the listed Hanbell approved oils. **POE oils readily absorb moisture and cause acid formation in the system. Keep oil exposure to the atmosphere to a minimum.**
- 3.4. **Installation of the Service/Stop Valve:** Unpack the service/stop valve's box then check against the list on the outside of the box to ensure correct parts. Be sure that all parts inside the carton are clean. Use the four bolts to secure the service/stop valve. Use PTFE sealer to seal the adapter while tightening it. Please refer to Figure 5-A for space requirements for future service and maintenance needs.

3.5. Service/stop Valve Recommended Connection

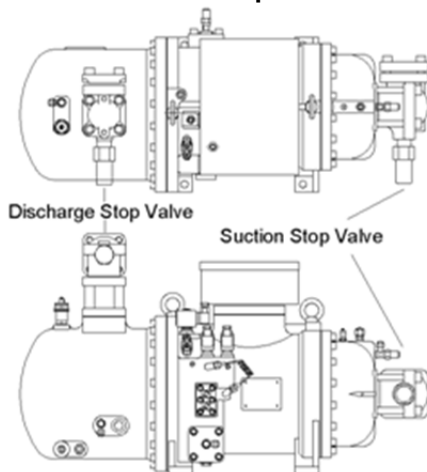

Figure 3-A RC2-100, 140 & 180

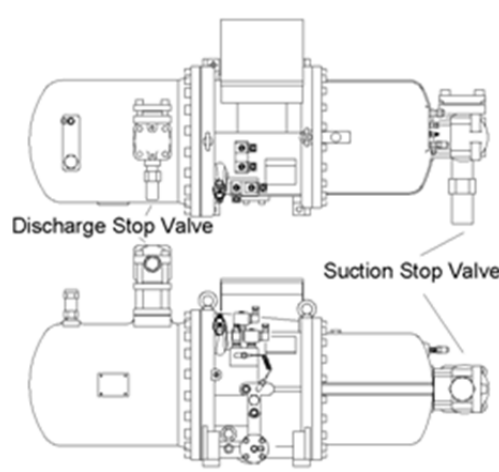

Figure 3-B RC2-170, 200~580 & 620

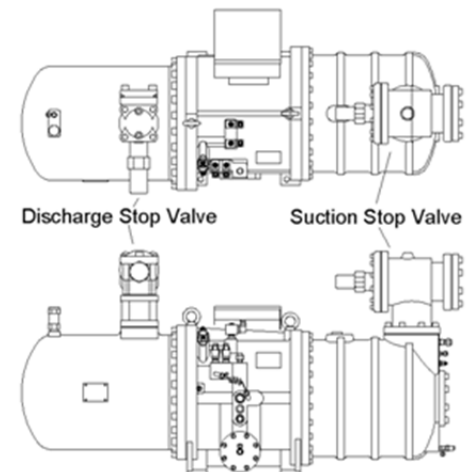

Figure 3-C RC2-610, 710~930

3.6. **Liquid Injection Solenoid Valve and Expansion Valve (optional accessories):** The liquid injection system may be piped, but it is necessary to consider the required space for adjustment of the expansion valve while testing or running the compressor. Please refer to installation guide in the following section for connection points.

3.7. **PTC Discharge Temperature Protection:** Each compressor comes standard with three PTC sensors in the motor windings and one located at the discharge port. A motor module (INT69HBY) is installed in the electrical terminal box. Refer to Figure 4-B showing the connection of motor and discharge PTCs in series to the motor module corresponding terminal blocks.

4. Recommended Liquid Injection Piping

Note:

RC2-100B, RC2-140B and RC2-180B have the Liquid Injection port on top.

Hanbell A&B Models	Liquid Injection Chamber Port Size
RC2-100 to RC2-930	3/8" Flare
RC2-1020 to RC2-1520	5/8" Flare

Desuperheating Valve	Connector Sizes
4403-13 and 4403-14	3/8" Flare

Liquid Injection Solenoid Valve Control on:

If Discharge Superheat < 10°F
Then Turn Off
Else If Discharge Temp > 180°F
OR
Motor Temp > 140°F
Then Turn ON
Else if Discharge Temp < 170°F
AND
Motor Temp < 120°F
Then Turn OFF

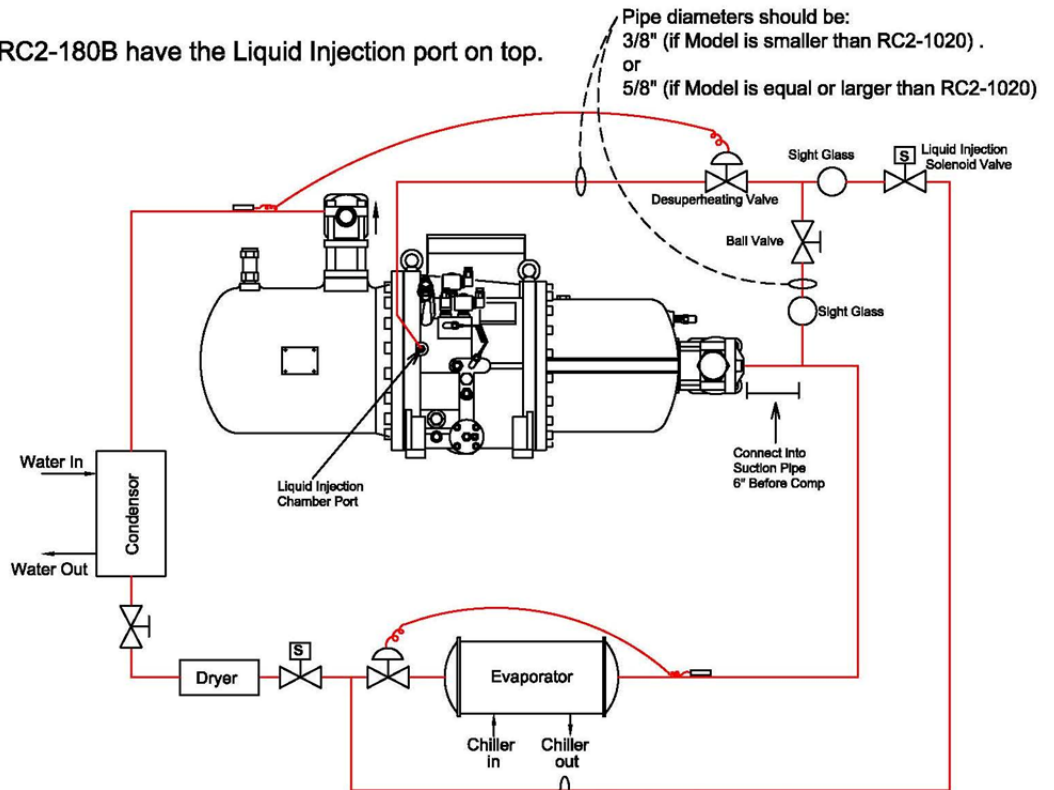

The liquid feed for the motor cooling and de-superheating valve must come off of the bottom of the liquid line. This will ensure that the line will have a full column of liquid refrigerant. Vapor refrigerant does not cool efficiently.

Pipe diameter should be:
5/8" (if Liquid Injection Chamber Port is 3/8")
or
7/8" (if Liquid Injection Chamber Port is 5/8")

MICRO CONTROL SYSTEMS Inc.	
Date:	04-28-11 Page 1 of 1
Drawn by:	W. Klebs
Revision :	D (07-26-11)
Dwg Name:	Hanbell Liquid Injection

Note A: It is necessary to adjust the Ball Valve to feed small amounts of liquid (drops) to the compressor motor.

5. Screw Compressor Wiring Procedures

Following the diagrams below will prevent damage to the electrical terminals and the possibility of personal injury.

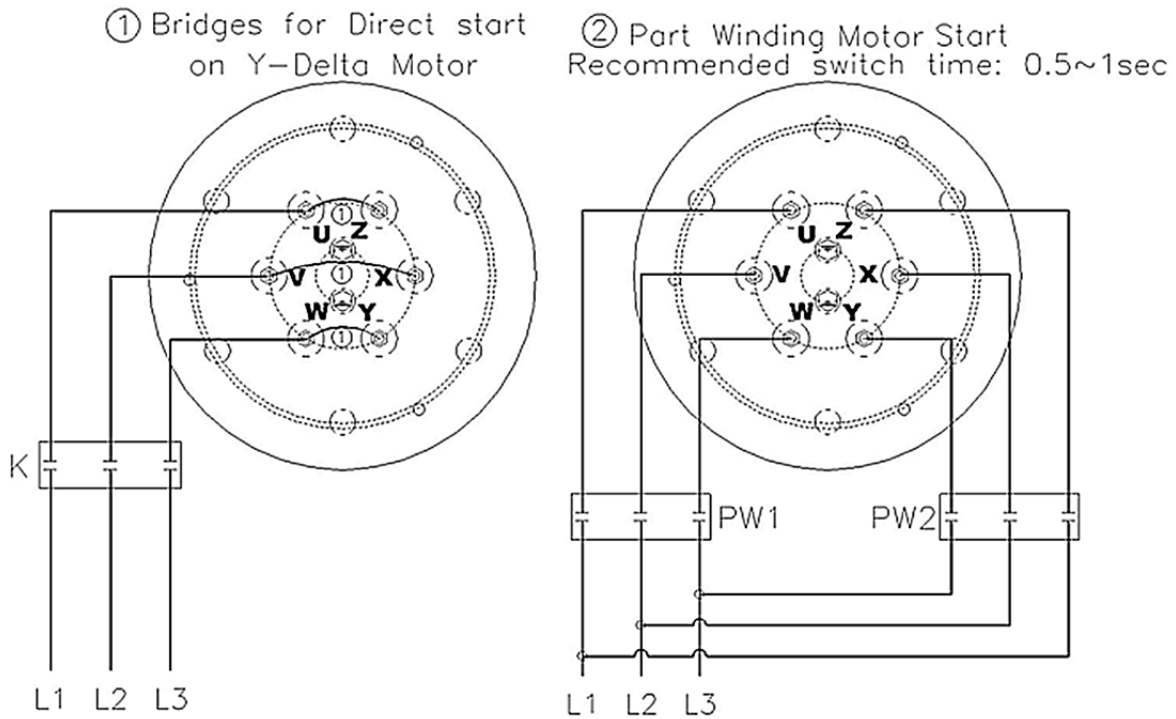

③ Y-Delta Motor Wiring

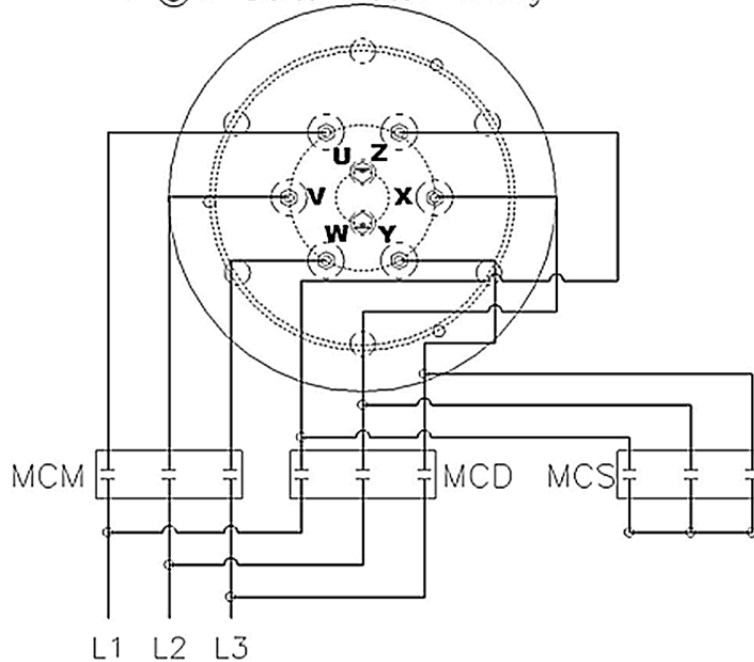



The method to tell the terminals:

1. By alphabet: Refer to the alphabet beside each terminal bolt in a star-delta motor.
2. By numbers: Refer to the number beside each bolt in a PWS motor.

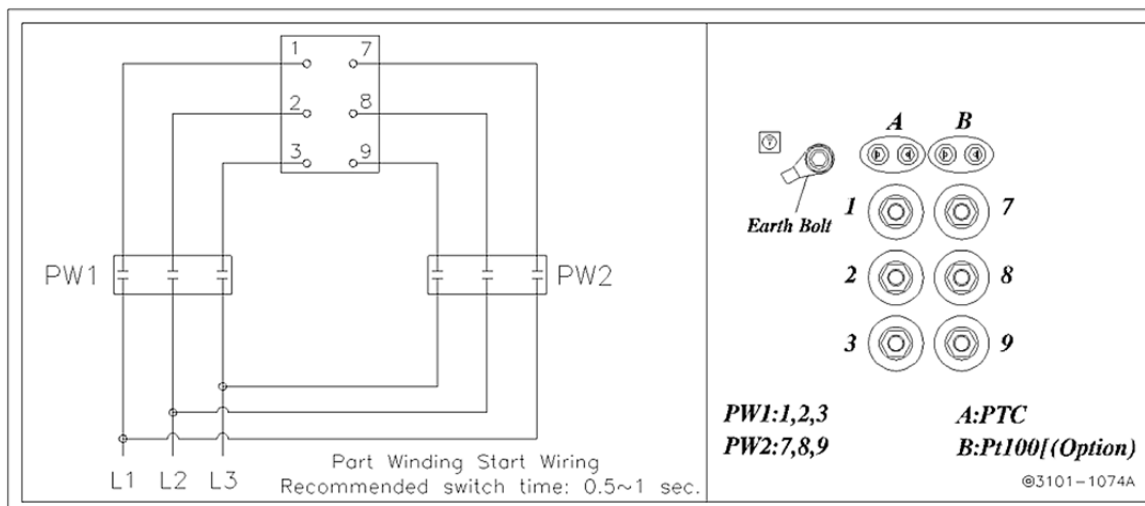
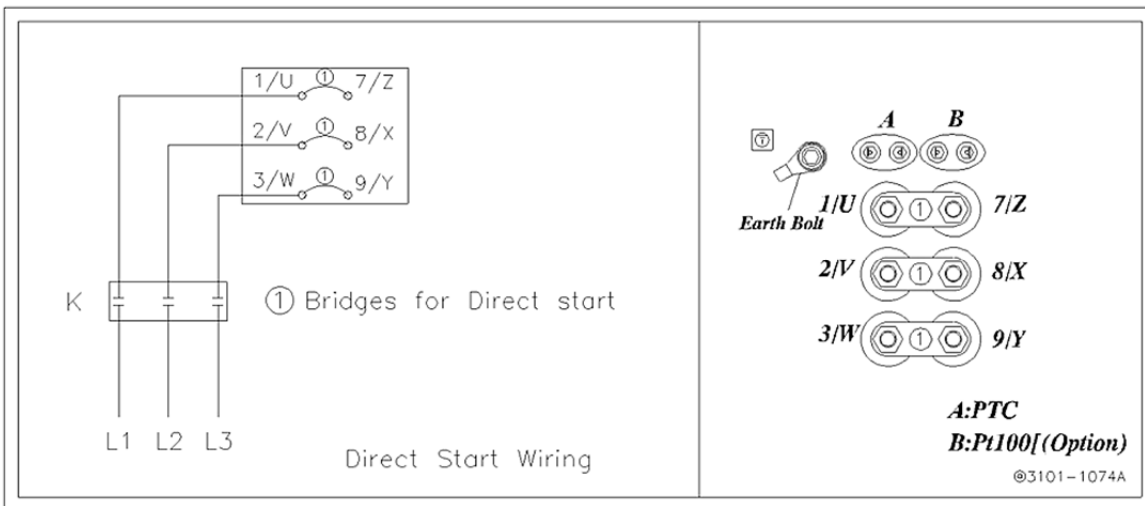
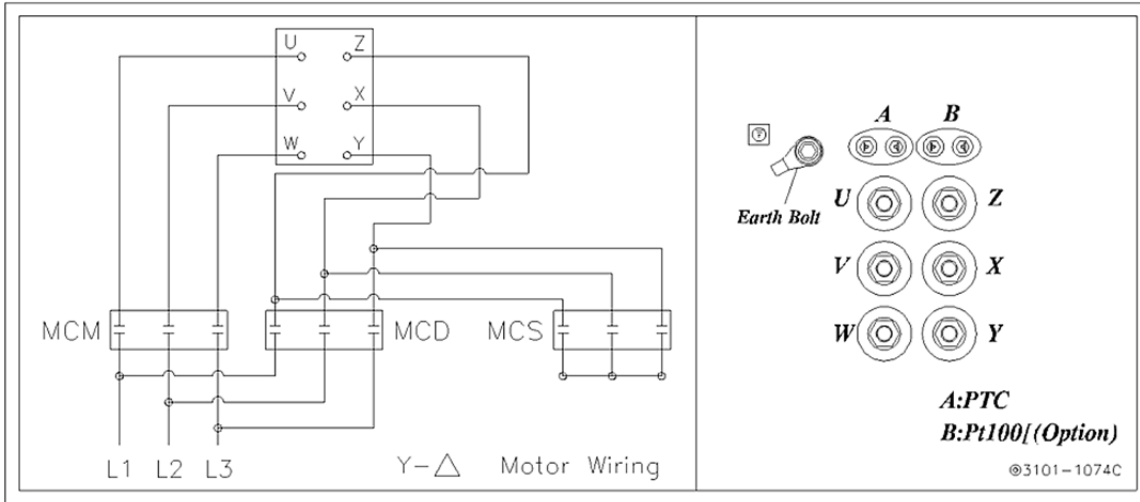
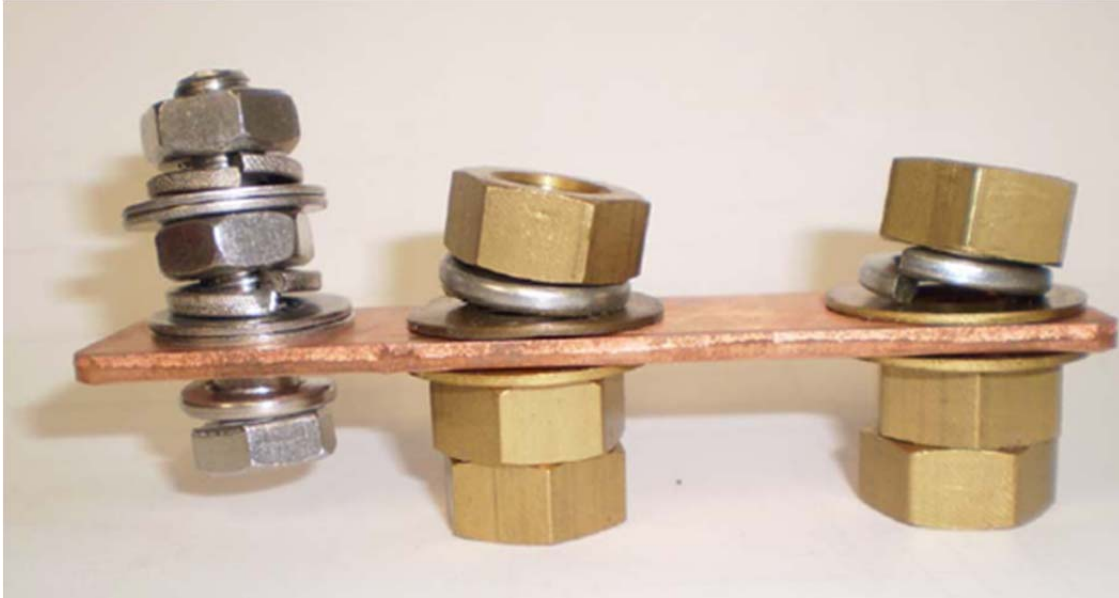
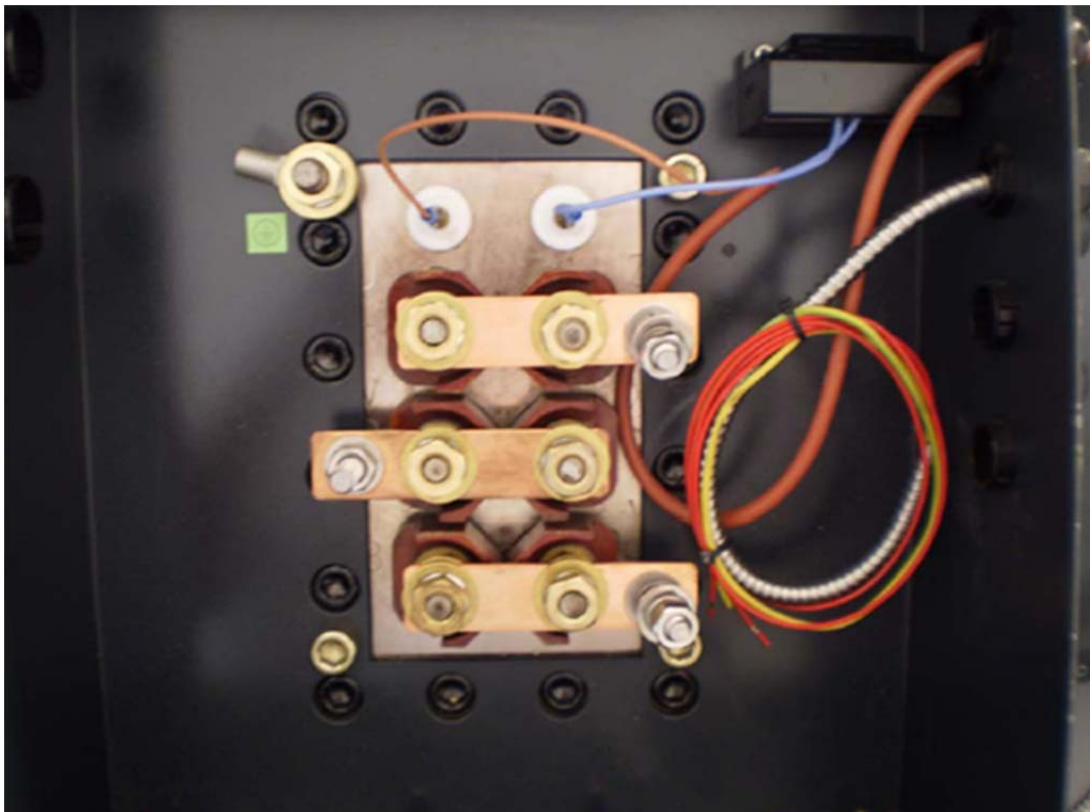

Figure 5-A Motor Wiring

Across the Line Jumper Bar Installation



Install extra nuts under jumper bar for clearance of power bolt insulation



INT69HBY WIRING DIAGRAM (Uses Power Interruption Reset Button)

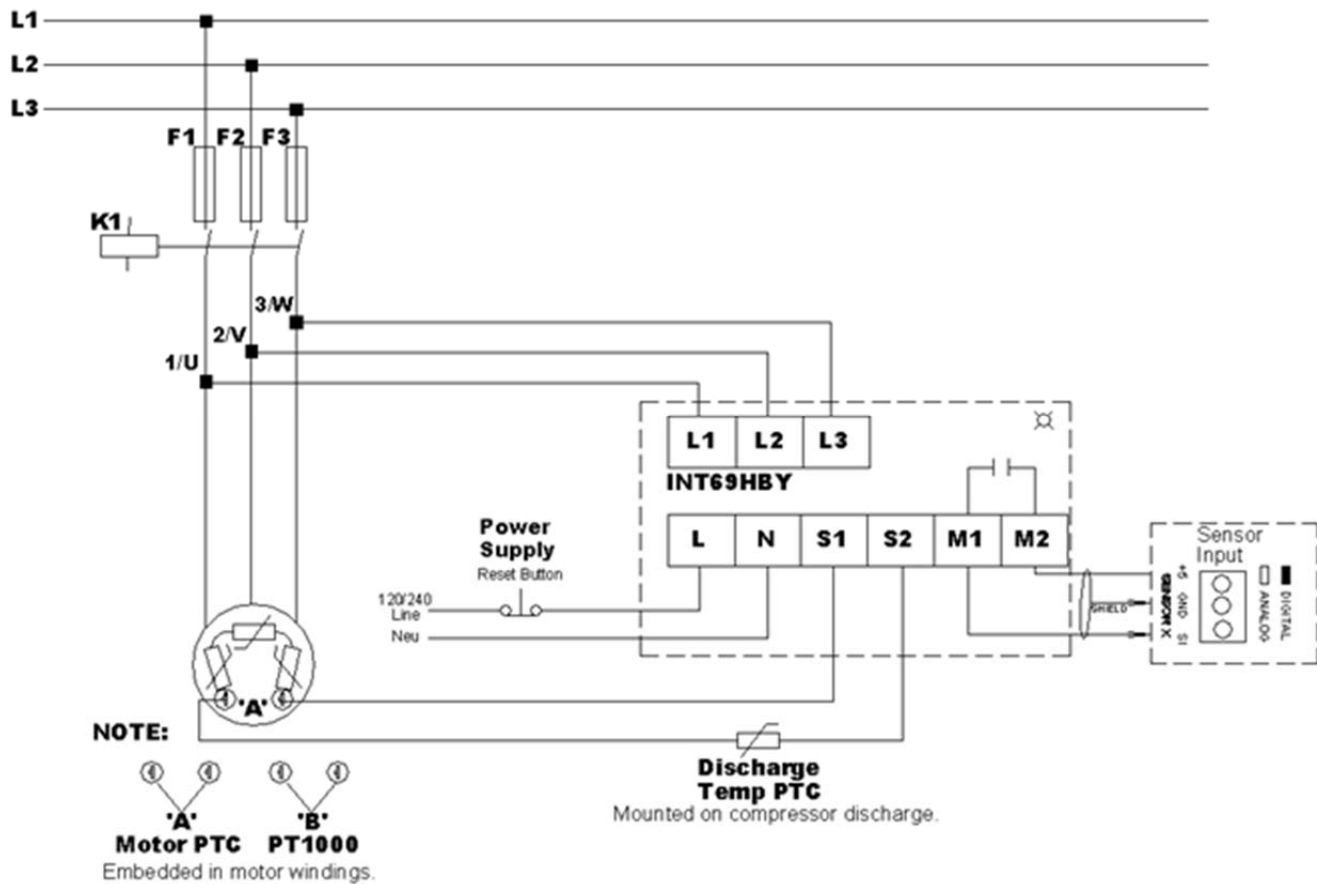

Figure 5-B Motor Protection Wiring

6. INT69HBY

The motor protector INT69HBY has been specially developed to monitor motor winding temperature, phase sequence and phase failure on compressors.

1. When supply voltage is applied, the output relay pulls in after an initialization period of approx. 3 seconds, provided all thermistors are below their rated response temperature.
2. There are 3 thermistors in the motor housing and 1 in the discharge neck, which are connected in series to the input terminals.
3. If any thermistor resistance increases above trip level the relay drops out. This failure results in a lockout. (5 minutes delay for 1st PTC failure, 60 minutes delay for 2nd failure, lockout for 3rd failure.)
4. If a rapid temperature increase is detected (locked rotor condition), the output relay drops out. This failure results in a lockout.
5. The phase monitoring function is active 1 second after motor start during a 10 second window. Incorrect phase sequence results in lockout trip. Phase loss results in lockout trip.
6. Lockout and time delay can be cancelled by mains reset of approx. 5 seconds.

7. To avoid nuisance tripping due to reverse running after shutdown (pressure equalization), the phase monitoring function is only re-enabled approx. 20 seconds after motor stop.
8. A twin LED (red / green) provides operational information.
9. The relay is fed out as a N/O dry contact, which is closed under good conditions.
10. Sensor and supply circuits are galvanic isolated.
11. The motor protector is not suitable for use with frequency converters.

Supply voltage -dual voltage	AC 50/60Hz 115/120V -15...+10% 3VA AC 50/60Hz 230/240V -15...+10% 3VA
Ambient temperature range	-30...+70°C
Temperature monitoring - Number of sensors - R 25, total - R trip static - R reset - max. lead length	PTC, to DIN 44081/082 1...9 in Series < 1.8kΩ 4.5kΩ ± 20% 2.75kΩ ± 20% < 30m
Time delay after cool down - static trip -dynamic trip(locked rotor)	lockout lockout
Phase monitor	3 AC 50/60Hz 200...575V ±10% active window : t ₀ + 1s...t ₀ + 11s
Phase sequence Phase loss	lockout lockout
Relay -AgNI 90/10	max. AC 240V, max. 2.5A, C300 min. >24V AC/DC, >20mA
Mechanical service life	approx. 1 mio. switching cycles
Protection class acc. to EN 60529	IP00
Connection	6.3mm connectors (Faston)
Housing material	PA66 GF25
Mounting	Screw mounted or latching
Dimensions	76.5x81.5x34.5mm
Weight	approx. 200g

Blink code INT69 HBY PTC

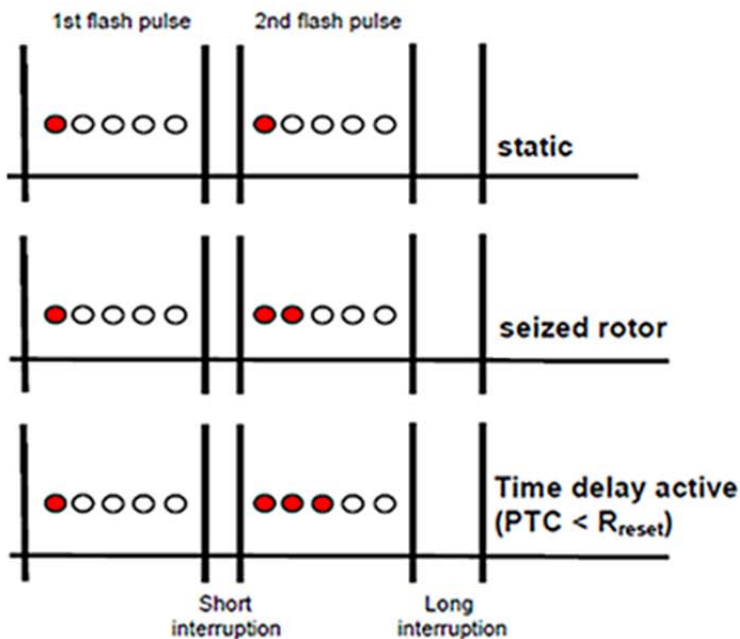

Phase monitoring / General

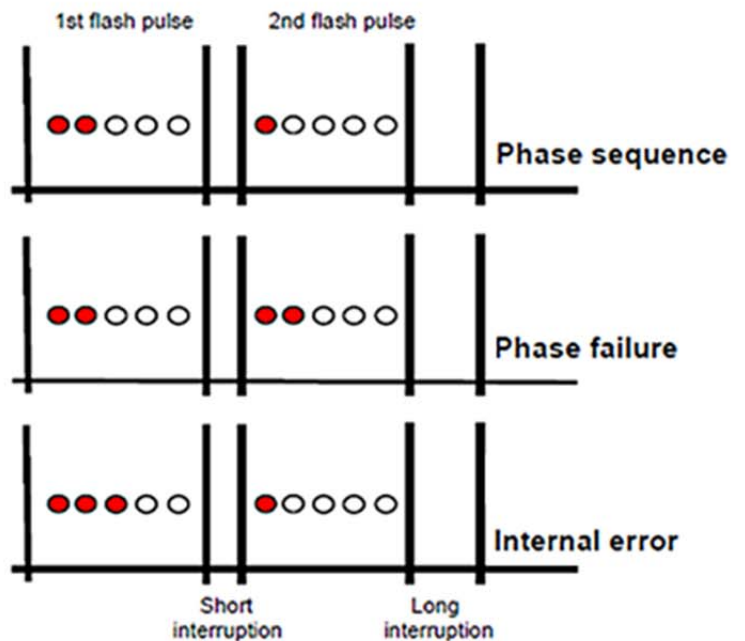

RC2-100,140 Installation Guide

◇ Capacity control system module :

A. Step-less capacity control:

1 (step-less) + 2 (33%)

B. 3 step capacity control:

2 (33%) + 3 (66%)

C. Step-less+step capacity control:

1 + 2 + 3

1. Solenoid valve only stepless

2. Solenoid valve 33%

3. Solenoid valve 66%

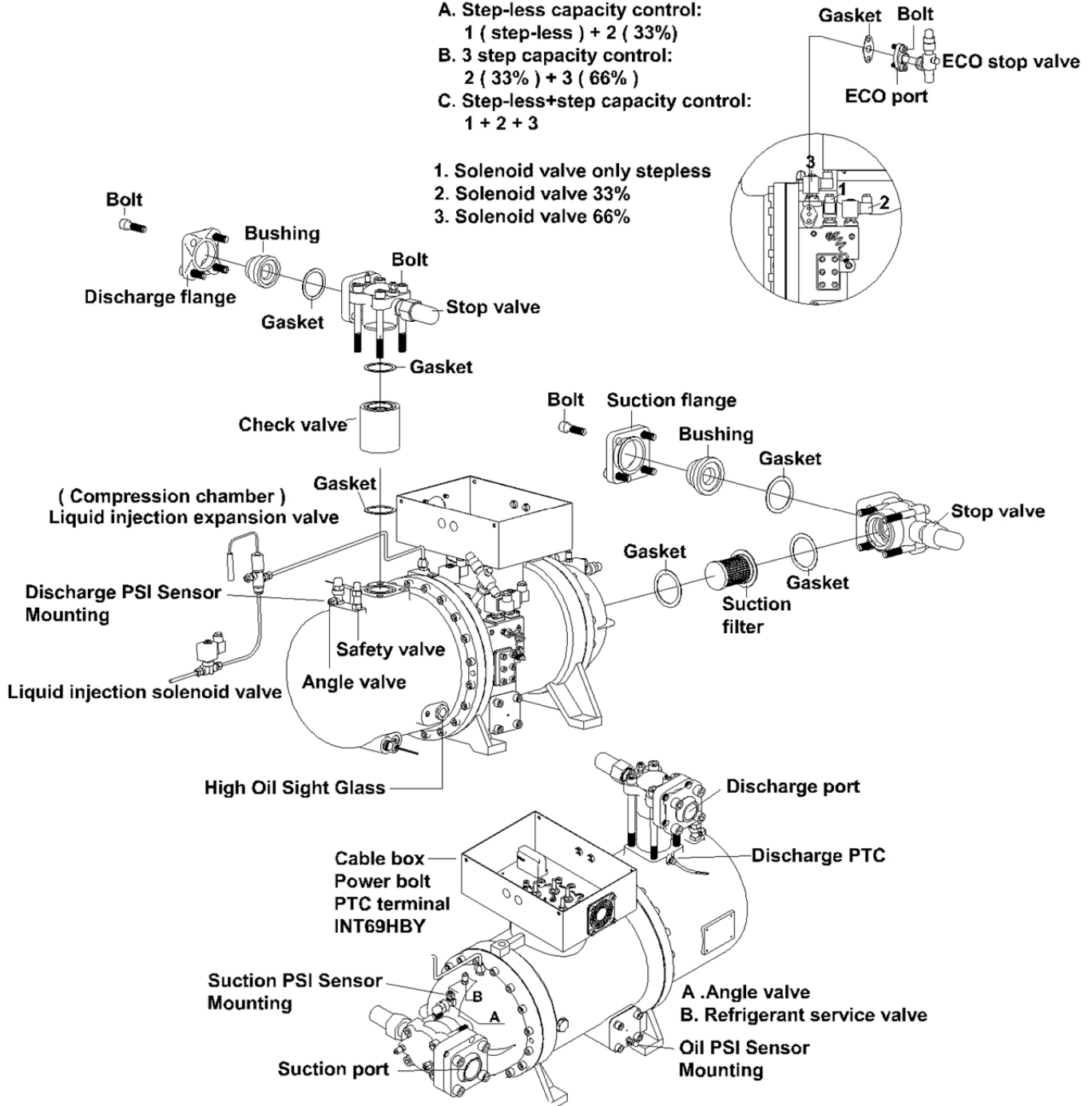

RC2-170~580 Installation Guide

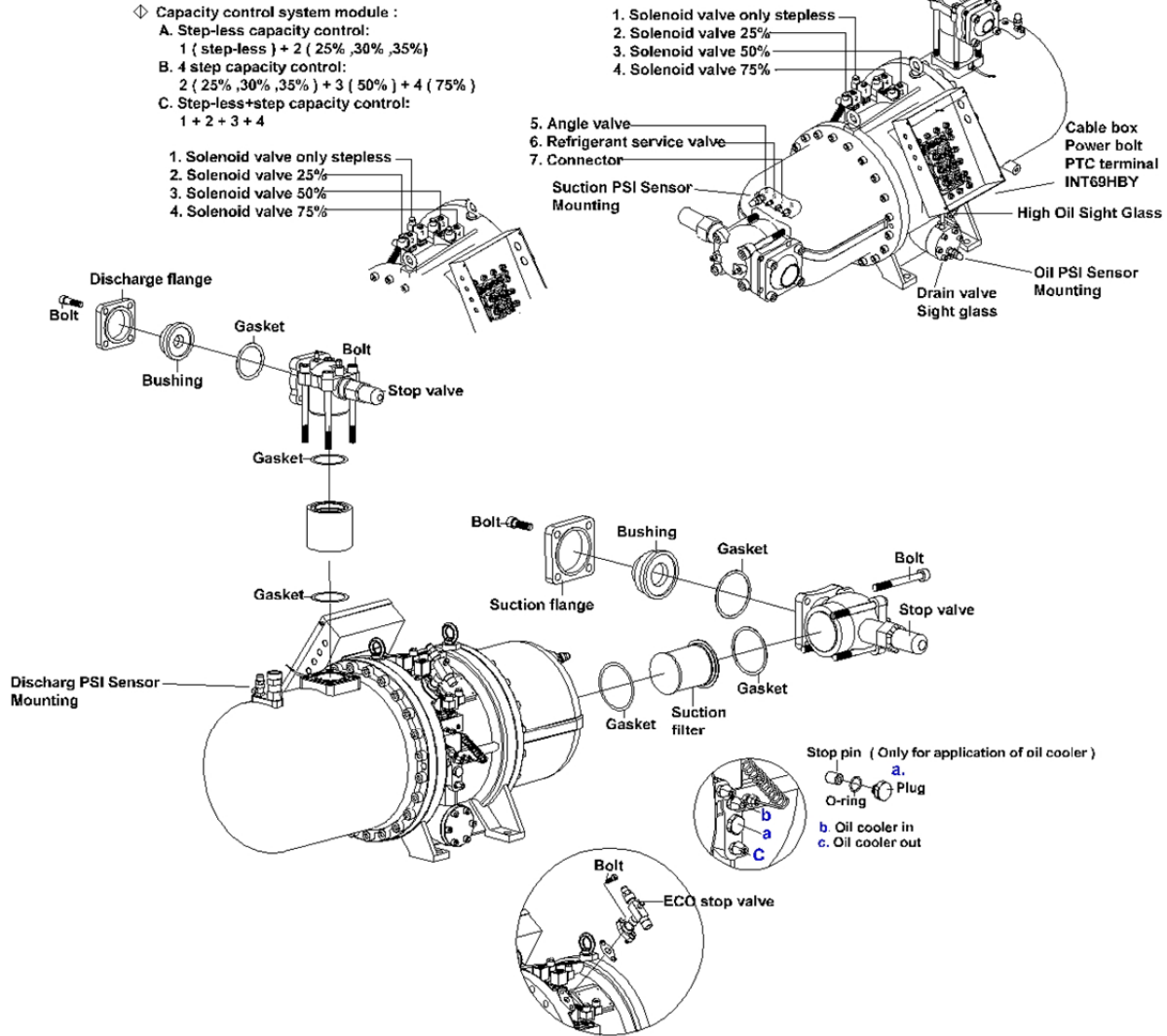

RC2-620 (The difference compared with RC2-170~580)

RC2-620 Suction side only

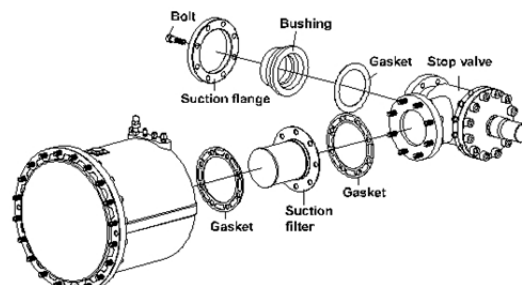

RC2-710~930 Installation Guide

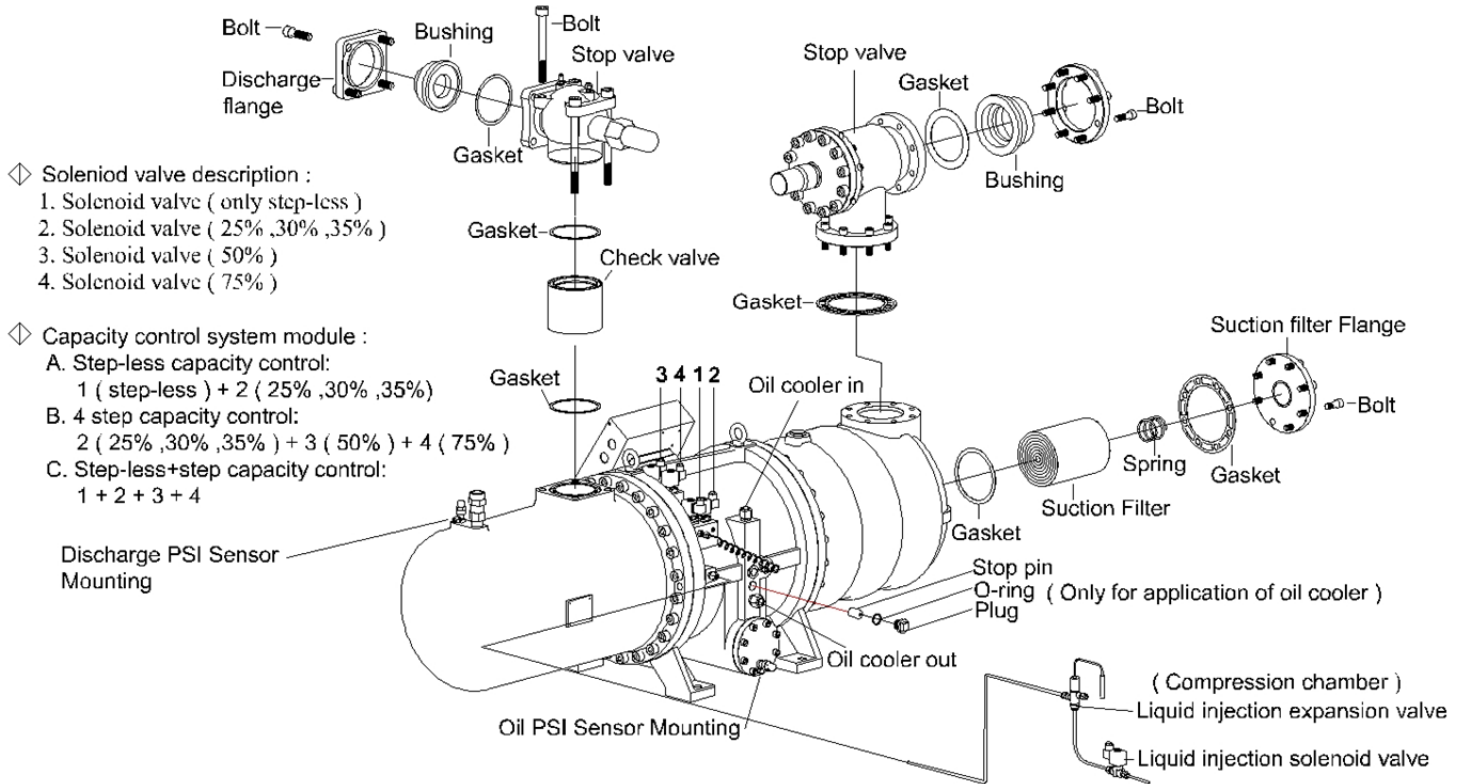

◇ Solenoid valve description :

1. Solenoid valve (only step-less)
2. Solenoid valve (25% ,30% ,35%)
3. Solenoid valve (50%)
4. Solenoid valve (75%)

◇ Capacity control system module :

- A. Step-less capacity control:
1 (step-less) + 2 (25% ,30% ,35%)
- B. 4 step capacity control:
2 (25% ,30% ,35%) + 3 (50%) + 4 (75%)
- C. Step-less+step capacity control:
1 + 2 + 3 + 4

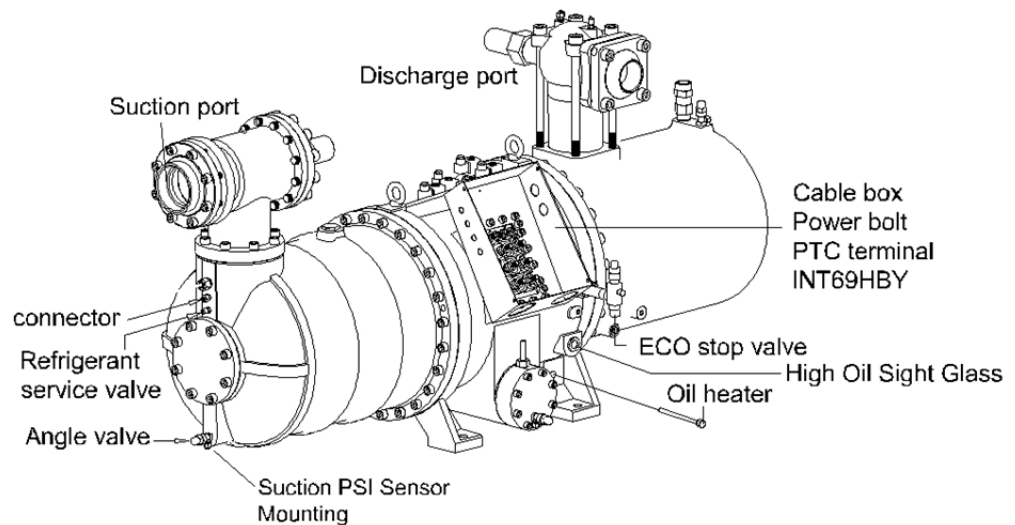

7. Maintenance Area Requirement

Please refer to the below tables for recommended minimum space requirements

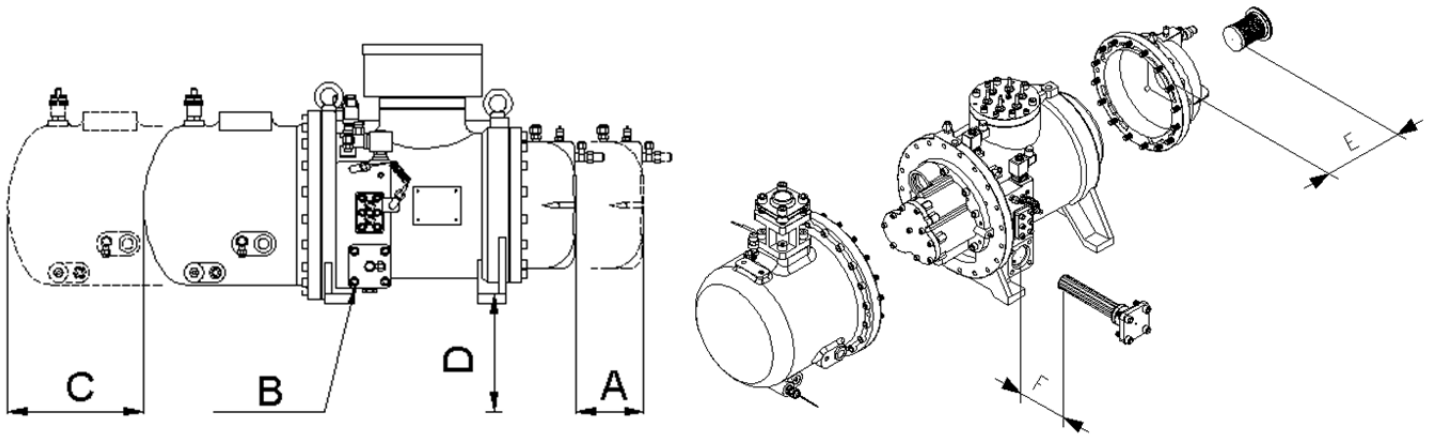

	RC2-100	RC2-140	RC2-180	RC2-170	RC2-200	RC2-230	RC2-260	RC2-300	
A.(cm)	5.9" (15)			16.1" (41)	18.1" (46)	18.5" (47)		20.1" (51)	
B.Outwards(cm)	11" (28)								
C.(cm)	9.8" (25)			10.2 (26)	11.8" (30)			13" (33)	
D.(cm)	5.9" (15)								
E.Suction filter(mm)	3.7" (95)				4" (103)		5.6" (143)		
F.Oil filter(mm)	7.8" (200)								
	RC2-310	RC2-320	RC2-340	RC2-370	RC2-410	RC2-470	RC2-510	RC2-550	
A.(cm)	20" (51)		22" (56)		21.3" (54)	23.3" (59)	21.7" (55)	23.3" (59)	
B.Outwards(cm)	11" (28)								
C.(cm)	13" (33)				11.8" (30)		13.8" (35)		14.6" (37)
D.(cm)	5.9" (15)								
E.Suction filter(mm)	5.6" (143)				6" (153)				
F.Oil filter(mm)	7.8" (200)								
	RC2-580	RC2-610	RC2-620	RC2-710	RC2-790	RC2-830	RC2-930		
A.(cm)	21.7" (55)	23.6" (60)	23.6" (60)	25.6" (65)			31.5" (80)		
B.Outwards(cm)	11" (28)	13.8" (35)	11" (28)	13.8" (35)					
C.(cm)	13.8" (35)	14.6" (37)		17.7" (45)					
D.(cm)	5.9" (15)	---	5.9" (15)	---					
E.Suction filter(mm)	6" (153)	8.2" (210)	6" (153)	8.2" (210)					
F.Oil filter(mm)	7.8" (200)	9.1" (232)	7.8" (200)	9.1" (232)					

Table 7-A Compressor Recommended Space for Maintenance

- 7.1. Reserve enough space for connection and installation of the electrical terminal box, service/stop valves and solenoid valves on the compressor.
- 7.2. Consider the compressors' future overhaul when determining space requirements. All compressors' outside parts and electrical controller lines and terminal connections etc should be spaced for easy dismantle and re-assemble.

Recommended Maintenance Schedule

Check Points	Running Period								
	24 hrs	1000 hrs	2500 hrs	5000 hrs	10000 hrs	15000 hrs	20000 hrs	25000 hrs	30000 hrs
Motor Insulation					○		○		○
Oil Filter Cartridge	○				○		○		○
Suction Filter	○								○
Piston Rings									△
Oil Level	○	○	○	○	○	○	○	○	○
PTC				○	○	○	○	○	○
Bearings					○		○		○/△

○ Check or Clean, △ Replace

Note: This table is only to be used as a rough estimate, not a basis for any claim. The most appropriate running period for each checkpoint is varied with operating condition (air-cooled or water-cooled), refrigerant, and lubricant (synthetic or mineral). Replacement of piston rings and bearings should be performed by Hanbell authorized technicians. When counts of piston loading and unloading motion are higher than 10,000 times, piston rings should be replaced immediately.

8. Compressor Piping

- 8.1. To avoid abnormal vibration and noise pay close attention to how the compressor is piped.
- 8.2. The welding for the compressor should contain at least 15% Argon as an ingredient. Once all piping is completed, perform a pressure test to ensure there are no leaks (maximum compressor pressure 350 psi or 24 bar). The **cleanliness** of the system after pipe welding should help avoid any swarf or debris operating inside the system that can cause compressor damage during operation.
- 8.3. To avoid compressor harmonic vibration transferred by the structure and piping to the chiller while in operation, a cushion or shock absorber should be installed on the suction and discharge tube.
- 8.4. Refer to Figure 6-A showing a 6mm to 15mm

shock absorber installed under the compressor-mounting pad to isolate the vibration and noise transferred to other portions.

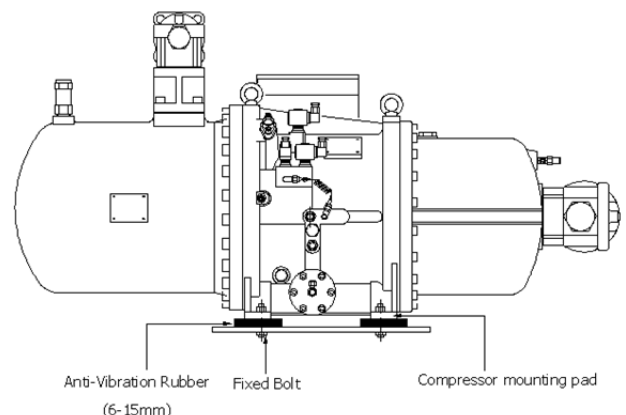

Figure 8-A Absorber Installation

8.5. In order to reduce vibration, copper tubes for suction and discharge pipes are recommended; copper suction and discharge pipes will minimize the vibration from the piping while the compressor is running. In the case of steel piping, it is very important for suitable welding to avoid the inner stress on piping due to harmonic vibration and noise, which will reduce the compressor life.

8.6. Remove oxidized impurities, swarf or debris caused by welding on piping tubes, if these impurities, swarf or debris are in the compressor, the oil filter will be clogged resulting in the lubrication system bearings and capacity control system malfunctioning.

8.7. The suction and discharge flanges are forged steel that can be welded directly with piping connectors (standard size for copper piping, if connecting to steel piping contact your Hanbell representative) After welding the flanges and pipes, they should be cooled down by ambient air; **water quenching is prohibited**. Do not use water to cool down the pipes and flanges after welding.

9. Electrical Wiring

If the compressor application is low voltage, the following items should be considered:

- 9.1. Use conduit to insulate and protect the main power cables between the control panel and compressors' electrical terminal box.
- 9.2. Press each main power cable connecting head with bolts firmly on each power terminal in electrical terminal box. Keep enough space and distance between the main power cable heads.
- 9.3. Choose suitable electrical accessories to meet the required critical running conditions. An **AC-3 contactor** is recommended to meet the rated capacity of power. Select an overload protector with a response time of **15 seconds** for overload.
- 9.4. Ensure the electricity voltage drop between each two phases is less than 2%. If unable to reduce the length of main power cable then a larger diameter of main power cable should be chosen. Please refer to Figure 7-A shown below.

Main power cable section area (mm ²)	8	14	22	30	38	50	60	80	100	125	150	200
Maximum continuous current (Amp)	55	80	100	125	145	175	200	230	270	310	360	425

Table 9-A Main Power Cable Size vs MCC

**Maximum main power cable temperature is at 60°C.
Maximum ambient temperature is at 35°C.**

9.5. To avoid any danger or accidents due to the shortage of electrical power, you are required to follow local Electrical Regulations for the grounding of the electrical terminal box, heater and compressor body etc.

9.6. The motor PTC and discharge PTC are temperature sensors with a quick response in relation to the temperature approach to their setpoint. The thermistors must be connected in series to a controller (INT69HBY – Kriwan provided with the compressor) in the terminal box for protection of the compressor. An alarm for the motor protector is required to be embedded on the control panel as an indicator. **Do not bypass/jump-out the INT69HBY to start and run the compressor.**

Warning: Wrong direction of rotation will cause severe compressor damage. Do not start the compressor without first reviewing the Start-up section of this document.

10. Pre-Start-up Procedure

- 10.1. Oil Charging: Only lubricants listed in Hanbell's Technical Manual are to be used. **NO SUBSTITUTES. Make sure the oil level is to the middle of the high side sight glass, which is the terminal box side of the compressor.** (For compressors with internal oil separators)
- 10.2. Oil Heater: The heater needs to be energized for 8 hours prior to running the compressor and energized when the compressor is off.
- 10.3. Make sure all valves are open (stop, angle valves with transducers, etc.)
- 10.4. Make sure all solenoids are wired correctly.
- 10.5. Make sure the motor module (INT69HBY) is wired correctly.
- 10.6. Make sure the electrical system is wired correctly and properly grounded.
- 10.7. Verify the controller is wired correctly. (Dry run)

Lubricant Charge

Model #	Oil Needed (In Gallons)
RC2-100	1.9
RC2-140	1.9
RC2-170	1.9
RC2-180	1.9
RC2-200	2.1
RC2-230	3.7
RC2-260	3.7
RC2-300	4.2
RC2-310	4.2
RC2-320	4.2
RC2-340	4.2
RC2-370	4.2
RC2-410	4.0
RC2-470	4.8
RC2-510	5.3
RC2-550	6.1
RC2-580	5.3
RC2-610	6.1
RC2-620	6.1
RC2-710	7.4
RC2-790	7.4
RC2-830	7.4
RC2-930	7.4
RC2-1090	N/A
RC2-1280	N/A
RC2-1520	N/A

Applicable oil types (R22)

SPECIFICATION	UNITS	TOTAL LUNARIA		SUN SUNISO		CPI SOLEST	CPI CP-4214		MOBIL SHC				
		58	68	4GS	5GS	170	100	150	320	68	120	220	
COLOR, ASTM		1.5	L2.0	L1.0	L1.0	-	-	-	-	L0.5	L0.5	L0.5	
SPECIFIC GRAVITY		0.883	0.883	0.914	0.925	0.95	0.96	1.01	1.05	0.834	0.838	0.846	
VISCOSITY	40°C	mm^2 / s	56.0	68.0	54.5	96.5	175	123	168	298	68	95	209
	100°C		(cSt)	7.0	7.8	6.07	8.12	16.5	14.2	20.2	32.0	10.0	13.7
FLASH POINT	°C	220		230	188	198	265	292	290	271	250	255	260
POUR POINT	°C	-40	-35	-35	-25	-30	-35	-43	-35	-45	-45	-39	
T.A.N	MgKOH/g	0.01	0.01	0.00	0.01	-	-	-	-	-	-	-	
COPPER STRIP	100°C/3hr	1a	1a	1a	1a	-	-	-	-	-	-	-	
MOISTURE	ppm	15	15	20	20	-	-	-	-	-	-	-	
FLOC POINT	°C	-75	-75	-45	-35	-	-	-	-	-	-	-	
DIELECTRIC STRENGTH	2.5mm	KV	75	70	50	50	46.6	-	-	-	-	-	

Applicable oil types (R134a, R404A, R407C)

SPECIFICATION	UNITS	CPI SOLEST				MOBIL EAL		ICI EMKARATE			
		68	120	220	370	68	100	RL411	RL375	RL421	
COLOR, ASTM		-	-	-	-	0.5	0.5	1.5	L2.0	L1.0	
SPECIFIC GRAVITY		0.945	0.94	0.95	0.955	0.971	0.966	0.9723	0.9783	0.9759	
VISCOSITY	40°C	mm^2 / s	64	131	215.9	385.96	62.5	95.8	48.0	74.1	134
	100°C		(cSt)	8.9	14.53	20.8	29.23	8.3	10.5	7.3	10.1
FLASH POINT	°C	266		254	271	302	254	260	273	246	265
POUR POINT	°C	-43	-36.5	-25	-21	-43	-37	-40	-35	-37	
T.A.N	mg KOH/g	-	-	-	-	-	-	<0.05	<0.05	<0.05	
COPPER STRIP	100°C/3hr	-	-	-	-	-	-	-	-	-	
MOISTURE	ppm	-	-	-	-	<100	<100	-	-	-	
FLOC POINT	°C	-	-	-	-	-	-	-	-	-	
DIELECTRIC STRENGTH	2.5mm	KV	-	-	-	-	-	-	-	-	

Note: For other applicable oil types, please consult with HANBELL first for approval

NOTE: RC2-AF, RC2-BF, and LA Series Compressors do not have an Oil Separator or Sump

These compressors do not hold oil and therefore have no oil filter, oil level switch, or heater. Therefore you must have an external oil separator with an oil sump and oil level float. Also, on the return line from the oil sump to the compressor you must have an oil filter and oil flow switch. Please follow the piping diagram below. Please ensure there is oil charged in the piping feeding the compressor to avoid a dry start-up.

To obtain high oil filtering efficiency, low pressure drop loss and non-interruption with lubricant supply system, the oil separator is built outside the compressor. The installation of lubricant circuit is a very important issue during the whole procedures. So, before starting, please make sure to read all the instructions of this manual carefully and ensure each step is done in accordance with the specifications.

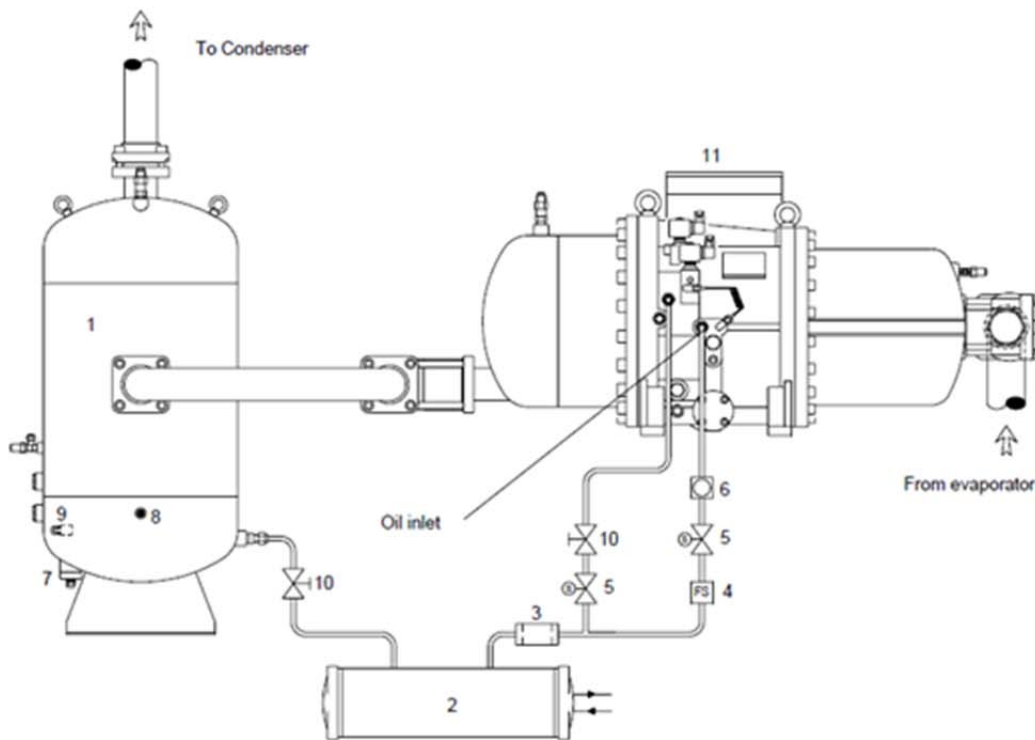

Illustration of RCF compressor and its external oil separator and accessories recommendation

1. External oil separator	7. Oil level switch
2. Oil cooler	8. Oil temperature sensor
3. Oil filter and cartridge	9. Oil heater
4. Lubricant flow switch	10. Manually adjustable flow valve
5. Oil solenoid valve	11. Compressor
6. Sight glass	

In the lubricant circuit, installing the oil solenoid valve in the proper place is very important. As the compressor is shut down, lubricant will automatically inject into the compressor due to pressure differential. It will easily make the system difficult to restart because of low oil level or lubricant injection inside the compressor chamber.

11. Start-up Procedure

- 11.1. Check the rotation of the compressor by starting for 1 second. The correct rotating direction is suction pressure drops and discharge pressure goes up. **Proper rotation is critical. If the compressor is operated in reverse, severe damage may occur.**
- 11.2. Recheck oil level. The oil level should be to the middle of the high side sight glass.
- 11.3. Hanbell recommends suction superheat 10°F to 20°F, discharge superheat 30°F and a pressure differential of at least 70 psig.

12. Recommended Safety Settings

- a) Motor Module Trip (INT69HBY): Open for 1 second
- b) Low Oil Level Float Trip: Open for 30-60 seconds
- c) Unsafe Suction: Less than 5 psi for 3 seconds
- d) High Discharge Temperature: Greater than 215°F for 2 seconds
- e) Low Differential Pressure: Less than 65 psi for 60 seconds
- f) Unsafe Differential Pressure: Less than 35 psi for 5 seconds
- g) Dirty Filter (Discharge Pressure - Oil Pressure): Greater than 20 psi for 30 seconds
- h) Low Discharge Superheat: Less than 25°F for 300 seconds

13. Hanbell with VFD

Please follow these guidelines when installing a Variable Frequency Drive (VFD) on a Hanbell compressor:

- 13.1. Do not connect the INT69HBY 3 phase sensor (red/white/blue wires).
- 13.2. Place the amp sensor(s) on the line side of the VFD.
- 13.3. Select only a constant torque VFD type to use.
- 13.4. Set for no Direct Current (DC) braking
- 13.5. Set Acceleration Time to 3-5 second

To setup a Hanbell RC2 series screw compressor to support a VFD:

1. Remove the 50% load solenoid coil (50% is no longer used).
2. The 25% load solenoid is used as the Fast Unload.
3. Remove the Load solenoid stem and install a Load Cap in its place.
4. Remove the red, white, and blue wires from the INT69HBY for the Phase Loss / Voltage safeties.

The final configuration should match the picture shown below:

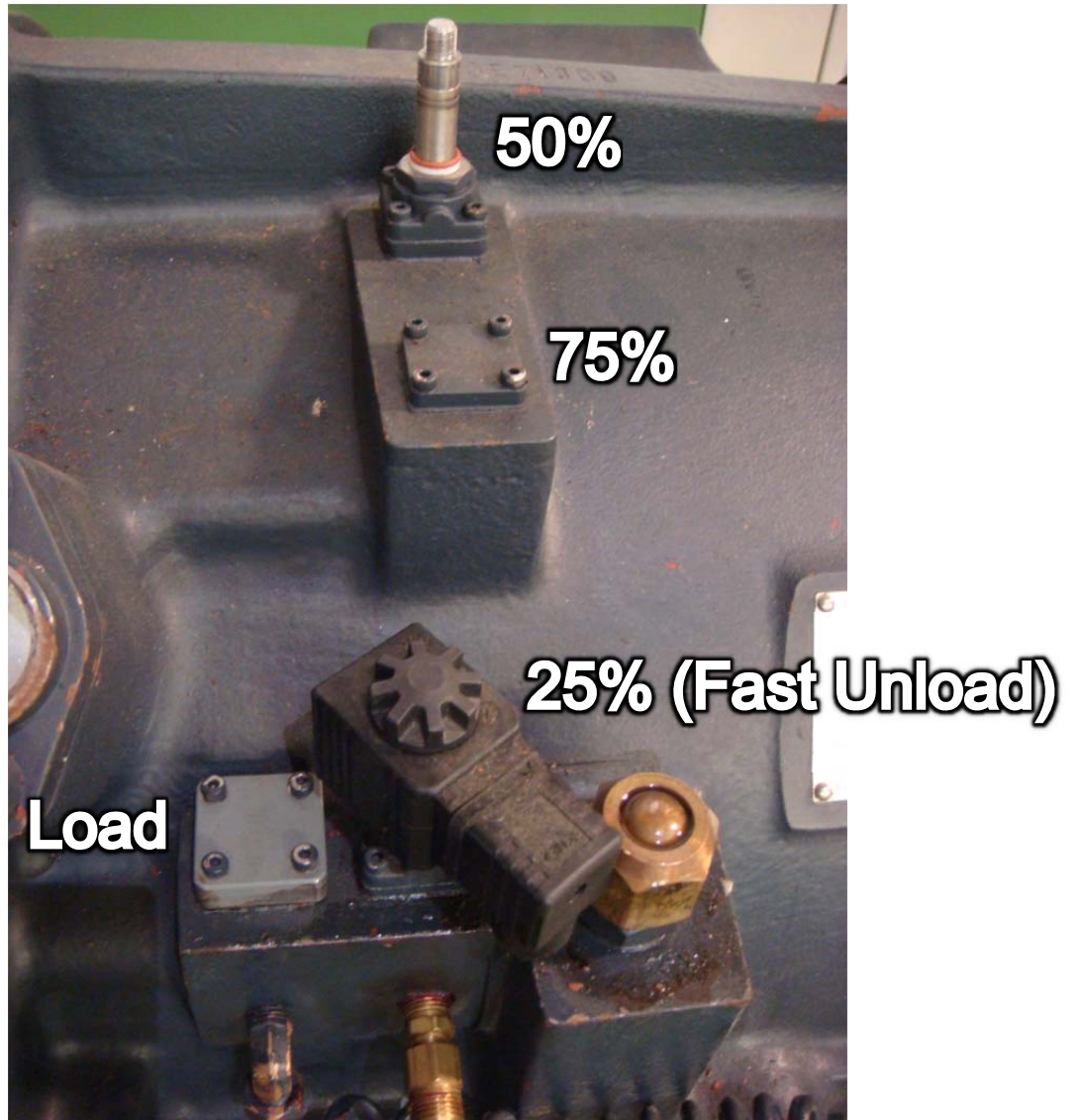

Solenoid Identification

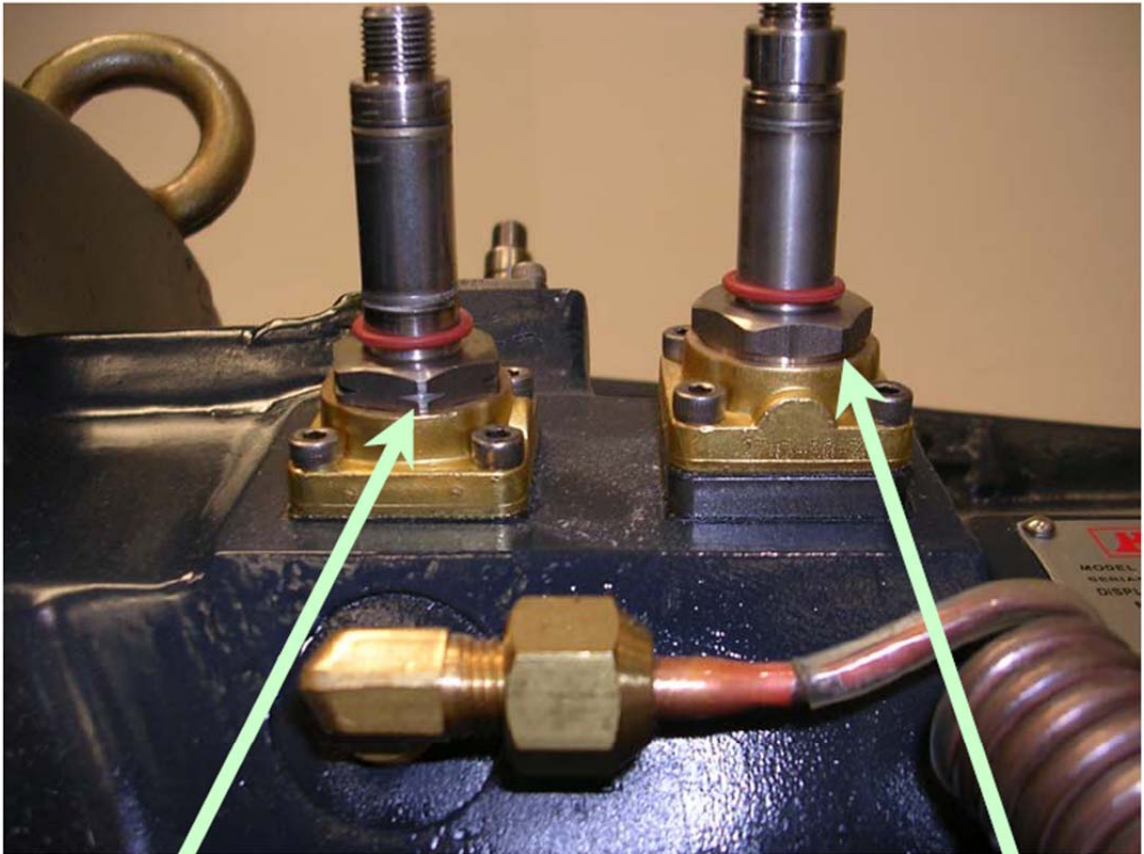

Normally open solenoid-
Can be identified by notches on nut.

Normally closed solenoid-
There are no notches on the nut.

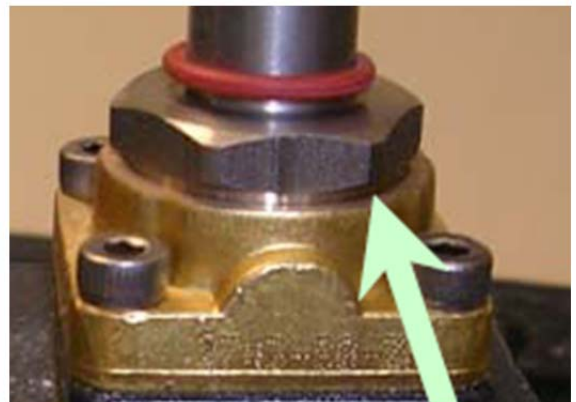
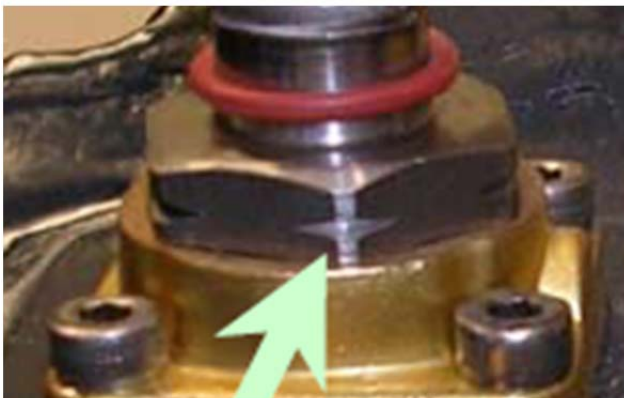

Infinite Capacity Minimum (50-100%)

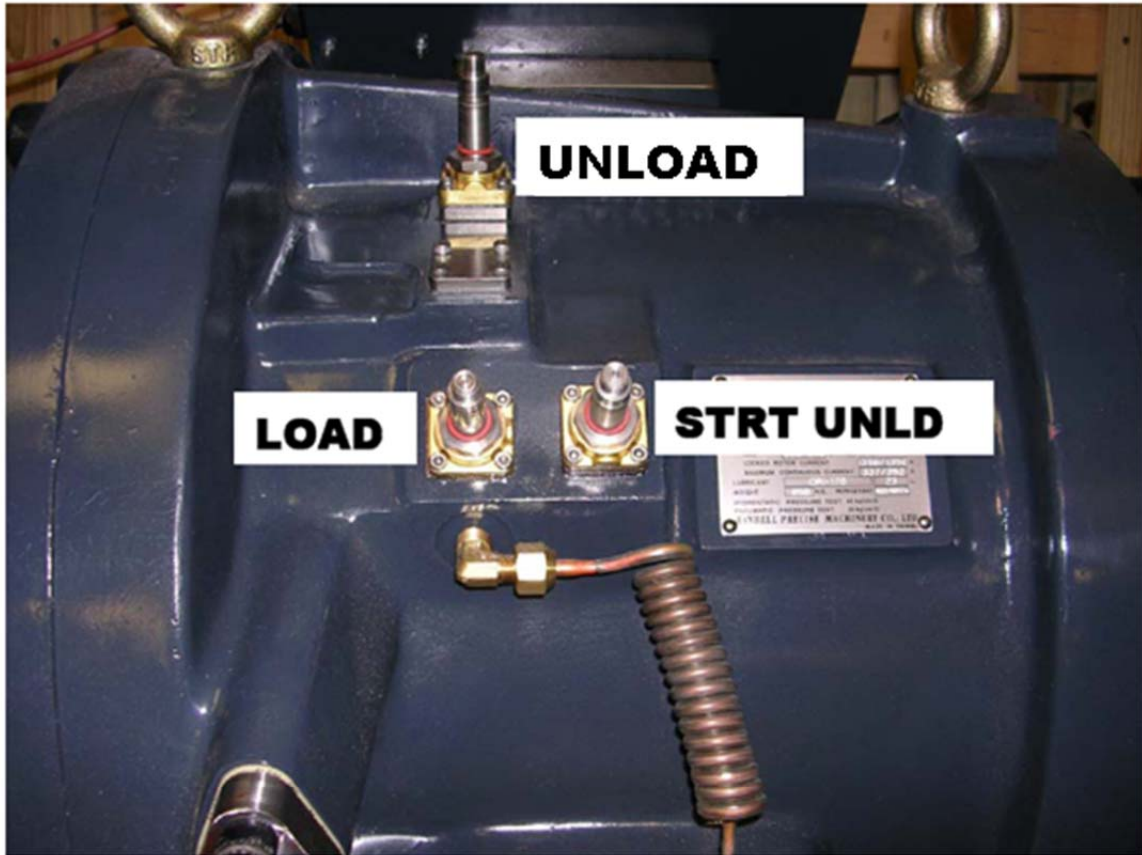

1. For New continuous (step less) capacity control system, Hanbell equipped all solenoid valves as Normally Closed. If it is necessary to be equipped with other type solenoid valve, please specify it with MCS / Hanbell before order confirmation.

Verify compressor load solenoid as Normally Open or Normally Closed.

2. If normally Open Solenoid, wire through the Normally Closed Relay Output.
3. If normally Closed Solenoid, wire through Normally Open Relay Output.

	UNLOAD(NC)	LOAD(NC)	STRT UNLD(NC)
Start	energize	Not energize	energize
Loading	Not energize	energize	Not energize
Unloading	energize	Not energize	Not energize
Stable	Not energize	Not energize	Not energize

Step Load 50%, 75%, 100%

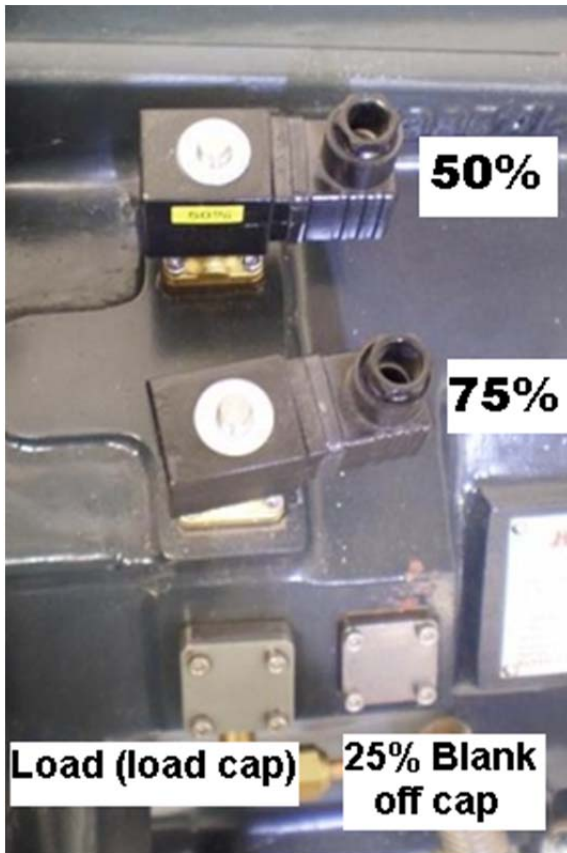

Step Load 25%, 50%, 75%, 100% (Only 25% at start-up and shut down)

See wiring diagram below

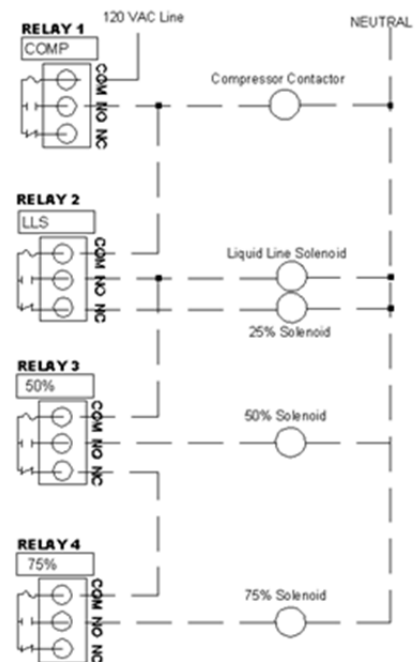
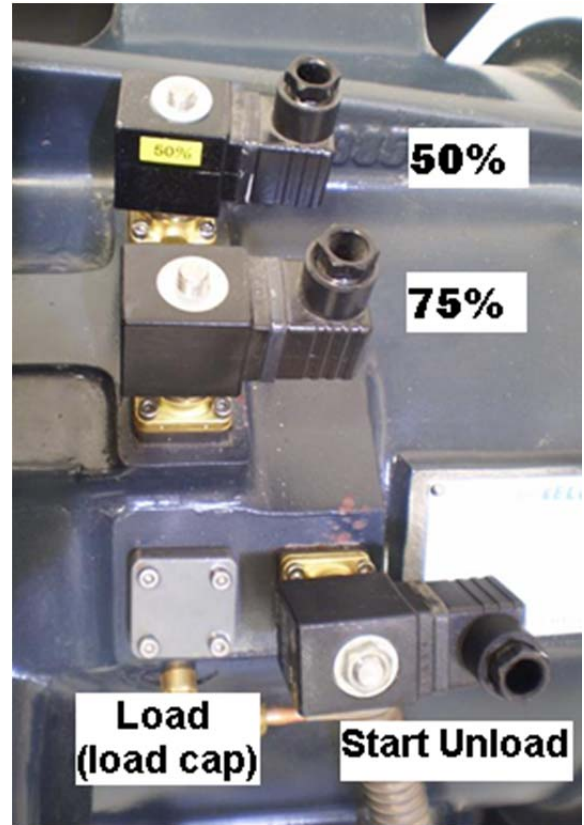

Solenoid Alignment

IMPORTANT: Solenoid alignment is critical to proper functioning of compressor

When installing solenoids on compressor, ensure that the holes match for proper oil flow to occur.



When installing Load Cap, make sure that the circular indent covers both of the compressor oil flow holes.

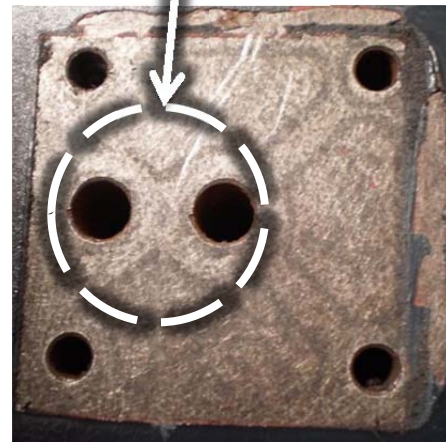

Also make sure holes line up if installing orifice plate.

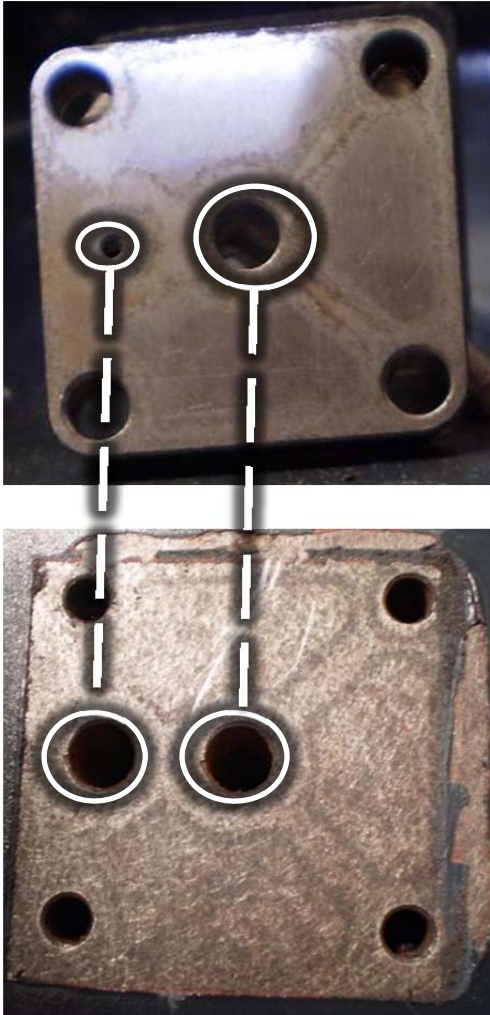

Proper installation of Solenoids With Orifice plate

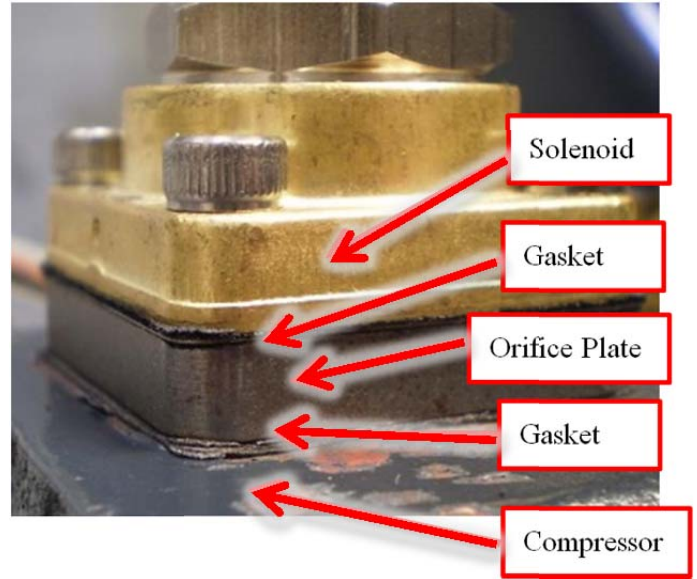

Without Orifice plate

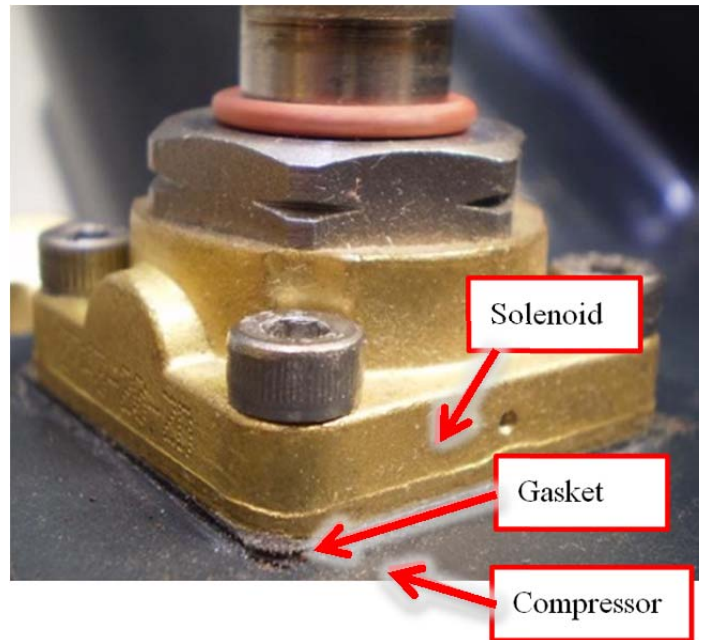

Not all oil flow holes are oriented the same way. Be sure to double check that the solenoid holes line up properly as shown below.





Warranty Start Up/Status Report

5877 Enterprise Parkway, Fort Myers, Florida 33905
 Phone: 239-694-0089 Fax: 239-694-0031

Upon startup, please complete form and email to: law@mcscontrols.com or fax to 239-694-0031

Company Name: _____

Sales Order # _____

Date _____

Job Site/Unit																																	
Street Address																																	
City																																	
Model Number											Serial Number			Model Number			Serial Number																
Unit 1											Unit 4																						
Unit 2											Unit 5																						
Unit 3											Unit 6																						
Temperature Readings													Volt / Pressure / AMP Readings																				
For Unit Information please see description above	Ambient Temp	Cond. Approach Temp	Cond. In Temp	Cond. Out Temp	Evap In Temp	Evap Out Temp	Oil Sump Temp	Cond. Sat Temp	Evap. Sat Temp	Sub Cooling Temp	Suction Super Heat Temp	Discharge Super Heat Temp	Discharge Temp	Suction Temp	Liquid Line Temp	Motor Temp	Evaporator Approach Temp	Volts L1 to L2	Volts L2 to L3	Volts L3 to L1	Refrig. Type	Run Hours	Oil Filter PSI	Oil PSI Differential	Discharge Pressure	Suction Pressure	Amps L1	Amps L2	Amps L3				
Unit 1																																	
Unit 2																																	
Unit 3																																	
Unit 4																																	
Unit 5																																	
Unit 6																																	

General Remarks

Customer Signature: _____